



THC6S High Energy Tantalum Hybrid Capacitor

(Hermetic sealed & Military standard)



❖ Characteristics and Application

- All tantalum case, hermetic sealed, square, small size, radial leads, polarized
- This product is made up of tantalum capacitor and electrochemical capacitor
- Stable electric performance, high reliability, long life, large energy density per unit volume, store much energy.
- Used as battery in energy conversion circuit and power pulse circuit. Perform energy storage, filter, power-off delay in circuit. Widely use in aircraft, radar, ship, tank, satellite, aerospace equipment etc.
- Standard: GJB733A-96, QJ/PWV500-2013, QJ/PWV519-2013, QJ/PWV518-2013

- ❖ **How to order:** **THC6S-10V220000μF-M 100PCS**
THC6SW-B-125V3000μF-M 100PCS

GT P/N definition:

THC6S: Square type without mount bolts tantalum hybrid tantalum capacitor

THC6SW-A: Square type with type A mount bolts tantalum hybrid tantalum capacitor

THC6SW-B: Square type with type B mount bolts tantalum hybrid tantalum capacitor

❖ Technical Performance

Temperature range: -55℃~+125℃ (+125℃ use derated voltage)

Store environment temperature: -62℃~+130℃

Capacitance tolerance: K=±10%; M=±20%; Q=-10%~+30%

❖ Mechanical Performance Characteristics

Mechanical Performance Characteristics		
Item	Test and Condition	Method and Requirement
Thermal shock	GJB360B-2009, method 107, test condition A	-55℃~125℃
(Pules) Shock	GJB360B-2009, method 213, test condition G	Final peak saw-tooth shock, last 11ms, peak 50g
Vibration - high frequency	GJB360B-2009, method 204, test condition D	Accelerated speed 20g, frequency range: 10~2000Hz
Vibration - random	GJB360A-96, method 214, test condition I -D	The acceleration root mean square value as 12g, 1.5h
Resistance to solder heat	GJB360B-2009, method 210, test condition B	The capacitor must withstand solder dipping of the terminals at 260 °C for 10s. The capacitor must not be visibly damaged and the electrical characteristics must not be affected.
Solderability	GJB360B-2009, method 208	
Terminal strength	GJB360B-2009, method 208, test condition A	The capacitor terminals must withstand a 14N pull for 30s. The capacitor must not be visibly damaged and the electrical characteristics must not be affected.
Part markings		Marks should be clearly marked on the circumference of the case of capacitor.



❖ Environmental Characteristics

Environmental Characteristics		
Item	Test and Condition	Method and Requirement
Hermeticity	GJB360B, method 112, test condition D	The capacitor surface shall have no continuous bubbles within 20s from it dipped into fluorocarbon oil, two areas are not included (a. the gaps between positive tantalum wires and sleeves b. gaps between stainless steel and tantalum shell). Test should keep on if there are bubbles from the two areas to check bubbles stop or go on after 5min. Hermeticity unqualified if it still bubbling. Take the capacitor out of fluorocarbon oil if bubbling stopped and check areas around positive wire and bubbling areas with PH paper. The capacitor hermeticity unqualified if PH paper turn red as acidic.
Moisture resistance	GJB360, method 106	6V polarity
Altitude	GJB360B, method 105, test condition E	Height: 45720m Air pressure: 0.15kPa.

Table 1 THC6S High Energy Tantalum Hybrid Capacitor Characteristics and Size: 35.5x35.5x8mm

Rated Voltage (V)	Derated Voltage (V)	Surge Voltage (V)	Cap. (μF)	tgδ(%) 100Hz	ESR (Ω) 1KHz	Max.DCL. (μA)		IMP. (Ω) 100Hz -55°C	Cap. change (%)		Max. Weight (g)
						25°C	85°C 125°C		-55°C	+85°C	
10	6	11	55000	180	0.05	170	1020	1.0	-75	140	65
16	9.5	17.6	35000	150	0.05	170	1020	1.0	-70	140	65
25	15	27.5	25000	120	0.05	170	1020	1.0	-65	120	65
35	20	38.5	14000	90	0.065	170	1020	1.0	-50	120	65
50	30	55	10000	65	0.07	200	1200	1.2	-45	120	65
63	38	70	5000	45	0.10	200	1200	1.4	-40	80	70
80	48	88	3300	40	0.10	200	1200	1.4	-30	80	70
85	51	93.5	3000	40	0.12	220	1320	1.6	-30	80	70
100	60	110	2200	35	0.13	220	1320	1.2	-25	60	75
110	66	121	2000	35	0.20	220	1320	2.0	-20	50	75
125	75	138	1400	35	0.20	220	1320	2.4	-18	50	80

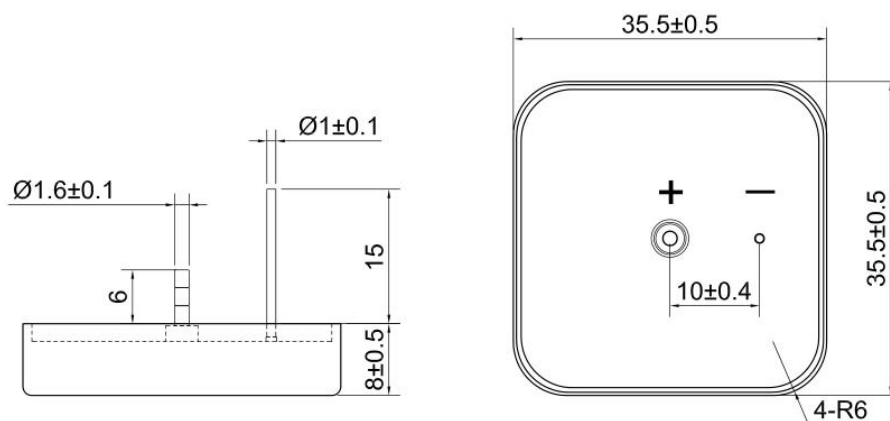

Dimensions: 35.5x35.5x8mm



Table 2 THC6S High Energy Tantalum Hybrid Capacitor Characteristics and Size: 35.5x35.5x12mm

Rated Voltage (V)	Derated Voltage (V)	Surge Voltage (V)	Cap. (μF)	tgδ(%) 100Hz	ESR (Ω) 1KHz	Max.DCL. (μA)		IMP. (Ω) 100Hz -55℃	Cap. change (%)		Max. Weight (g)
						25℃	85℃ 125℃		-55℃	+85℃	
10	6	11	120000	180	0.04	400	2400	1	-80	160	90
16	9.5	17.6	86000	165	0.04	400	2400	1	-80	160	90
25	15	27.5	50000	130	0.045	400	2400	1	-75	160	90
35	20	38.5	33000	95	0.05	400	2400	1	-70	160	90
50	30	55	20000	70	0.05	500	3000	1.2	-55	135	90
63	38	70	10000	50	0.05	500	3000	1.4	-45	90	95
80	48	88	6800	40	0.06	600	3600	1.6	-40	90	95
85	51	93.5	6000	40	0.07	600	3600	1.6	-40	90	95
100	60	110	4500	35	0.08	600	3600	1.8	-30	80	100
110	66	121	4000	35	0.08	600	3600	2.0	-25	60	100
125	75	138	3000	30	0.08	600	3600	2.4	-25	50	110

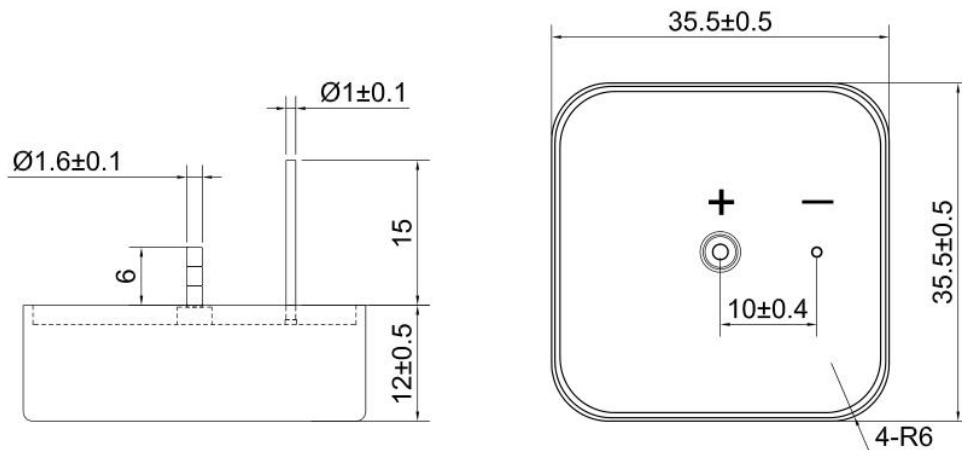

Dimensions: 35.5x35.5x12mm



Table 3 THC6S High Energy Tantalum Hybrid Capacitor Characteristics and Size: 35.5x35.5x16mm

Rated Voltage (V)	Derated Voltage (V)	Surge Voltage (V)	Cap. (μF)	tgδ(%) 100Hz	ESR (Ω) 1KHz	Max.DCL. (μA)		IMP. (Ω) 100Hz -55℃	Cap. change (%)		Max. Weight (g)
						25℃	85℃ 125℃		-55℃	+85℃	
10	6	11	200000	180	0.025	400	2400	1	-80	160	123
16	9.5	17.6	130000	165	0.025	400	2400	1	-80	160	123
25	15	27.5	75000	130	0.035	400	2400	1	-75	160	123
35	20	38.5	50000	95	0.035	400	2400	1	-70	160	123
50	30	55	30000	70	0.035	500	3000	1.2	-55	135	123
63	38	70	16000	50	0.035	500	3000	1.4	-45	90	125
80	48	88	10000	40	0.04	600	3600	1.6	-40	90	125
85	51	93.5	9000	40	0.05	600	3600	1.6	-40	90	125
100	60	110	7000	35	0.05	600	3600	1.8	-30	80	130
110	66	121	6000	35	0.075	600	3600	2.0	-25	60	130
125	75	138	4200	30	0.065	600	3600	2.4	-25	50	140

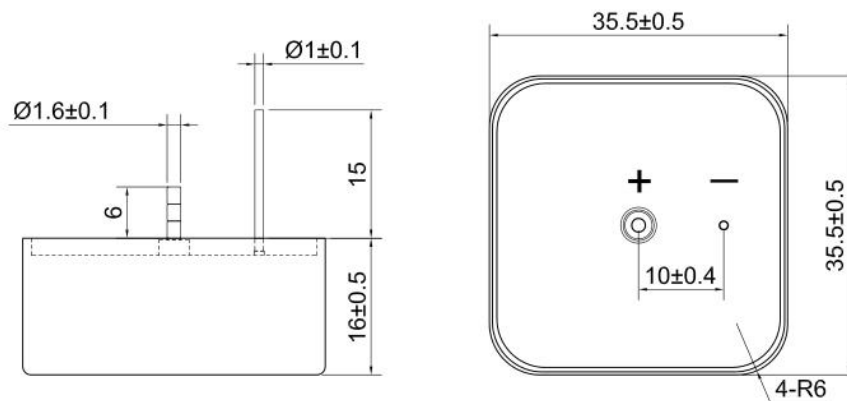

Dimensions: 35.5x35.5x16mm



Table 4 THC6S High Energy Tantalum Hybrid Capacitor Characteristics and Size: 35.5x35.5x20mm

Rated Voltage (V)	Derated Voltage (V)	Surge Voltage (V)	Cap. (μF)	tgδ(%) 100Hz	ESR (Ω) 1KHz	Max.DCL. (μA)		IMP. (Ω) 100Hz -55℃	Cap. change (%)		Max. Weight (g)
						25℃	85℃ 125℃		-55℃	+85℃	
10	6	11	220000	190	0.025	500	3000	1.0	-80	160	148
16	9.5	17.6	140000	170	0.025	500	3000	1.0	-80	160	148
25	15	27.5	100000	140	0.03	500	3000	1.0	-75	160	148
35	20	38.5	56000	100	0.03	500	3000	1.0	-70	160	148
50	30	55	40000	75	0.03	600	3600	1.2	-60	160	148
63	38	70	20000	55	0.035	600	3600	1.4	-50	100	150
80	48	88	14000	45	0.04	700	4200	1.6	-40	100	150
85	51	93.5	12000	45	0.04	700	4200	1.6	-40	100	150
100	60	110	9000	40	0.05	700	4200	1.8	-30	80	155
110	66	121	8000	40	0.06	700	4200	1.8	-25	60	155
125	75	138	5600	35	0.06	700	4200	2.0	-25	50	165

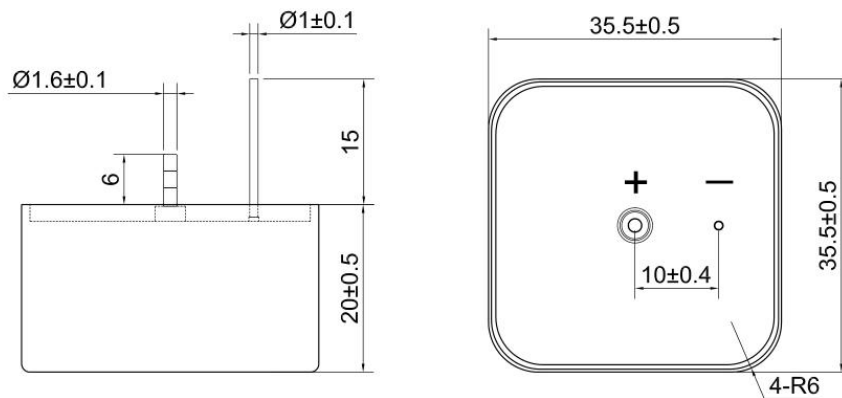

Dimensions: 35.5x35.5x20mm



❖ Optional Bolt Mount

Module	Leads and bolt height /mm
Type A	6.0±1.0
Type B	4.5±1.0

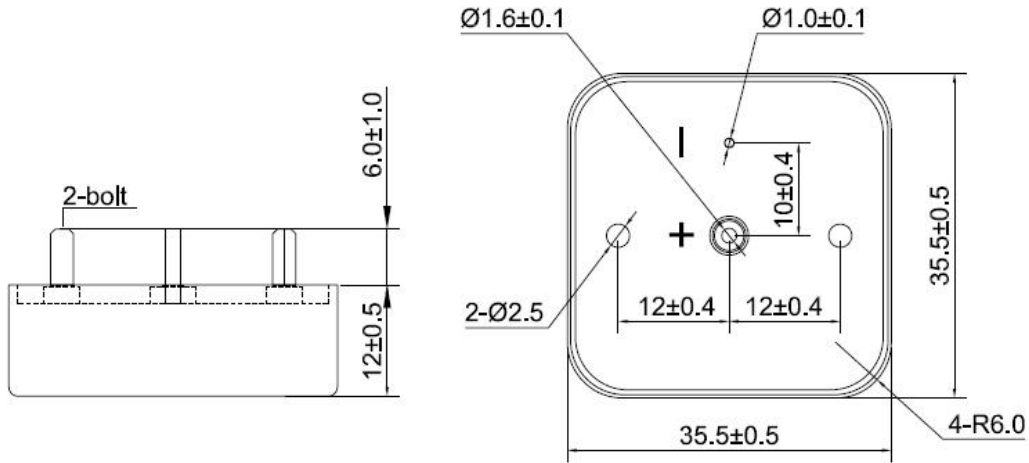

Type A

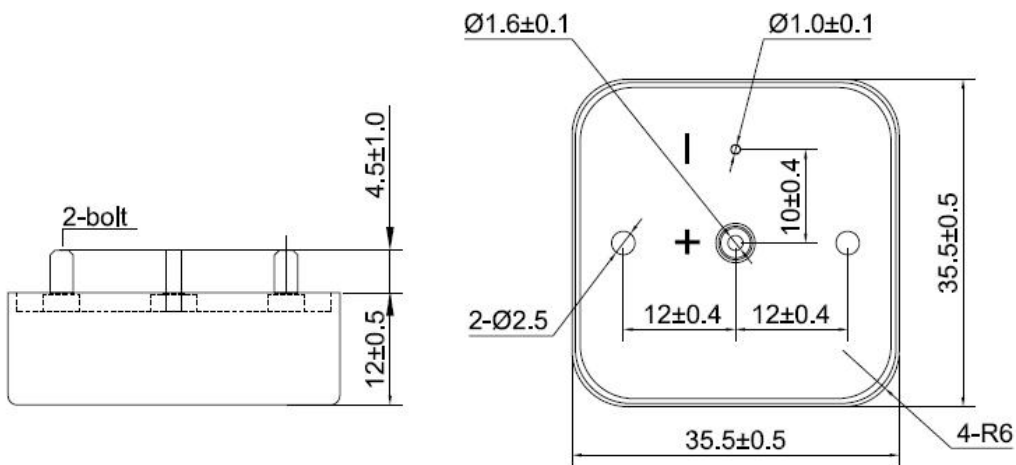

Type B

Notes:

- Tantalum capacitors can't be measured by multimeter. (Easily cause irreversible damage and lead to reject when reversed polarity);
- Capacitance, DF measure frequency: 100Hz, DC offset voltage $U=2.2^{0.10}V$, Exchange offset voltage $U=1.0^{0.05}V$ (effective value), measure method is by series equivalent circuit.
- Measure the leakage current at 125°C, please use derated voltage. DCL. value read at 5 minute.
- Special size and big capacitance products, please consult with GTCAP.